

Technical Evaluation Report™

TER 2307-04

Power Pro® Structural Wood Screws for Ledger Connections

The Hillman™ Group

Products:

**Power Pro® LedgerTite® Structural Wood Screws,
Power Pro® Structural Lag Screws, and Power
Pro® TimberWood Structural Screws**

Issue Date:

October 17, 2023

Revision Date:

October 17, 2023

Subject to Renewal:

October 1, 2024



Use the QR code to access the most recent version or a sealed copy of this Technical Evaluation Report (TER) at drjcertification.org.



COMPANY
INFORMATION:

ADDITIONAL
LISTEES:

The Hillman™ Group
1280 Kemper Meadow Dr
Cincinnati, OH 45240-1632

P: 513-851-4900

info@hillmangroup.com

www.hillmangroup.com

DIVISION: 06 00 00 - WOOD, PLASTICS AND COMPOSITES

SECTION: 06 11 00 - Wood Framing

SECTION: 06 05 23 - Wood, Plastic, and Composite Fastenings

SECTION: 06 15 00 - Wood Decking

1 Innovative Products Evaluated^{1,2}

- 1.1 Power Pro® LedgerTite® Structural Wood Screws
- 1.2 Power Pro® Structural Lag Screws
- 1.3 Power Pro® TimberWood Structural Screws

2 Applicable Codes and Standards^{3,4}

2.1 Codes

- 2.1.1 *IBC—15, 18, 21: International Building Code®*
- 2.1.2 *IRC—15, 18, 21: International Residential Code®*

2.2 Standards and Referenced Documents

- 2.2.1 *ANSI/AWC NDS: National Design Specification (NDS) for Wood Construction*
- 2.2.2 *ASTM A153: Standard Specification for Zinc Coating (Hot-Dip) on Iron and Steel Hardware*
- 2.2.3 *ASTM D1761: Standard Test Methods for Mechanical Fasteners in Wood*
- 2.2.4 *ASTM F1575: Standard Test Method for Determining Bending Yield Moment of Nails*
- 2.2.5 *AWC TR12: General Dowel Equations for Calculating Lateral Connection Values*

¹ For more information, visit drjcertification.org or call us at 608-310-6748.

² **Federal Regulation Definition.** 24 CFR 3280.2 "Listed or certified" means included in a list published by a nationally recognized testing laboratory, inspection agency, or other organization concerned with product evaluation that maintains periodic inspection of production of listed equipment or materials, and whose listing states either that the equipment or material meets nationally recognized standards or has been tested and found suitable for use in a specified manner. **International Building Code (IBC) Definition of Listed.** Equipment, materials, products or services included in a list published by an organization acceptable to the building official and concerned with evaluation of products or services that maintains periodic inspection of production of listed equipment or materials or periodic evaluation of services and whose Listing states either that the equipment, material, product or service meets identified standards or has been tested and found suitable for a specified purpose. **IBC Definition of Labeled.** Equipment, materials or products to which has been affixed a label, seal, symbol or other identifying mark of a nationally recognized testing laboratory, approved agency or other organization concerned with product evaluation that maintains periodic inspection of the production of the above-labeled items and whose labeling indicates either that the equipment, material or product meets identified standards or has been tested and found suitable for a specified purpose.

³ This Listing is a code defined research report, which is also known as a duly authenticated report, provided by an approved agency (see IBC Section 1703.1) and/or an approved source (see IBC Section 1703.4.2). An approved agency is "approved" when it is ANAB accredited. DrJ Engineering, LLC (DrJ) is listed in the ANAB directory. A professional engineer is "approved" as an approved source when that professional engineer is properly licensed to transact engineering commerce. Where sealed by a professional engineer, it is also a duly authenticated report certified by an approved source. (i.e., Registered Design Professional). DrJ is an ANAB accredited product certification body.

⁴ Unless otherwise noted, all references in this Listing are from the 2021 version of the codes and the standards referenced therein. This material, product, design, service and/or method of construction also complies with the 2000-2021 versions of the referenced codes and the standards referenced therein.

3 Performance Evaluation

- 3.1 Tests, test reports, research reports, duly authenticated reports and related engineering evaluations are defined as intellectual property and/or trade secrets and protected by Defend Trade Secrets Act 2016 (DTSA).⁵
- 3.2 Testing and/or inspections conducted for this TER were performed at an ISO/IEC 17025 accredited testing laboratory,⁶ an ISO/IEC 17020 accredited inspection body,⁷ which are internationally recognized accreditations through International Accreditation Forum (IAF), and/or a licensed Registered Design Professional (RDP).
- 3.3 Power Pro® LedgerTite® Structural Wood Screws, Power Pro® Structural Lag Screws, and Power Pro® TimberWood Structural Screws were evaluated to determine:
 - 3.3.1 Use for attachment of deck ledgers to the building structure. This application includes attachments to Spruce Pine-Fir (SPF) band joists⁸ and Oriented Strand Board (OSB) band joists.
 - 3.3.2 Lateral strength of ledger connections to wood-framed walls. This application includes zero, one, or two layers of 5/8" Gypsum Wallboard (GWB) between the ledger and the wall studs.
- 3.4 For conventionally framed buildings, the deck ledger is required to be attached to the band joist in accordance with IBC Section 1604.8.3 or IRC Section R507.9,⁹ as applicable.
 - 3.4.1 Where a band joist is not used as in some truss installations, an engineered design is required.
- 3.5 Any building code and/or accepted engineering evaluations (i.e. research reports, duly authenticated reports, etc.) that are conducted for this Listing were performed by DrJ Engineering, LLC (DrJ), an ISO/IEC 17065 accredited certification body and a professional engineering company operated by RDPs / approved sources. DrJ is qualified¹⁰ to practice product and code compliance services within its scope of accreditation and engineering expertise, respectively.
- 3.6 Engineering evaluations are conducted with DrJ's ANAB accredited ICS code scope, which are also its areas of professional engineering competence.
- 3.7 Any regulation specific issues not addressed in this section are outside the scope of this TER.

⁵ <https://www.law.cornell.edu/uscode/text/18/part-11/chapter-90>. Given our professional duty to inform, please be aware that whoever, with intent to convert a trade secret (TS), that is related to a product or service used in or intended for use in interstate or foreign commerce, to the economic benefit of anyone other than the owner thereof, and intending or knowing that the offense will, injure any owner of that trade secret, knowingly without authorization copies, duplicates, sketches, draws, photographs, downloads, uploads, alters, destroys, photocopies, replicates, transmits, delivers, sends, mails, communicates, or conveys such information; shall be fined under this title or imprisoned not more than 10 years, or both. Any organization that commits any offense described in subsection (a) shall be fined not more than the greater of \$5,000,000 or 3 times the value of the stolen trade secret to the organization, including expenses for research and design and other costs of reproducing the trade secret that the organization has thereby avoided. The federal government and each state have a public records act. As the National Society of Professional Engineers states, "Engineers shall not disclose, without consent, confidential information concerning the business affairs or technical processes of any present or former client or employer, or public body on which they serve." Therefore, to protect intellectual property (IP) and TS, and to achieve compliance with public records and trade secret legislation, requires approval through the use of Listings, certified reports, technical evaluation reports, duly authenticated reports and/or research reports prepared by approved agencies and/or approved sources. For more information, please review this website: Intellectual Property and Trade Secrets.

⁶ Internationally recognized accreditations are performed by members of the International Accreditation Forum (IAF). Accreditation Body and Regional Accreditation Group Members of IAF are admitted to the IAF MLA only after a stringent evaluation of their operations by a peer evaluation team, which is charged to ensure that the applicant complies fully with both international standards and IAF requirements. Once an accreditation body is a signatory of the IAF MLA, it is required to recognize certificates and validation and verification statements issued by conformity assessment bodies accredited by all other signatories of the IAF MLA, with the appropriate scope.

⁷ Ibid.

⁸ The term "band joist" is used throughout this report. Other regional terms synonymous with band joist include rim board, band board, header board, and header joist.

⁹ 2015 IRC Section R507.2

¹⁰ Qualification is performed by a legislatively defined Accreditation Body. ANSI National Accreditation Board (ANAB) is the largest independent accreditation body in North America and provides services in more than 75 countries. DrJ is an ANAB accredited product certification body.

4 Product Description and Materials

4.1 The innovative products evaluated in this TER are shown in Figure 1, Figure 2 and Figure 3.



Figure 1. Power Pro® LedgerTite® Structural Wood Screw



Figure 2. Power Pro® Structural Lag Screw

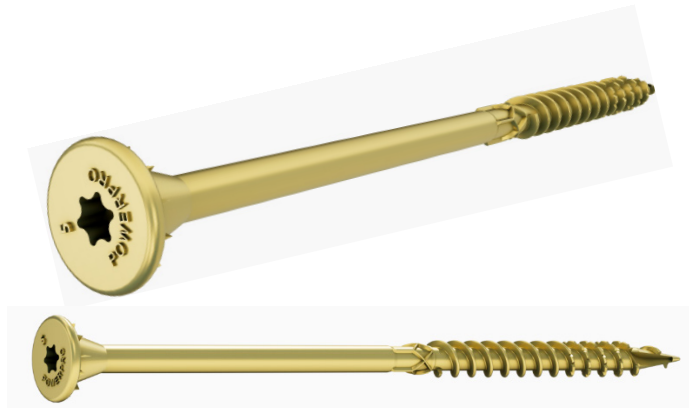

Figure 3. Power Pro® TimberWood Structural Screw

4.2 General

- 4.2.1 Power Pro® LedgerTite® Structural Wood Screws, Power Pro® Structural Lag Screws, and Power Pro® TimberWood Structural Screws are partially-threaded, self-drilling, dowel-type fasteners that are manufactured using standard cold-forming processes and are subsequently heat-treated and coated with a proprietary coating comprising of a zinc layer and an organic topcoat.
- 4.2.2 LedgerTite® fasteners are $5/16$ " hex-driven screws with an integrated washer.
- 4.2.3 Structural Lag Screws are Torx-driven screws with a flattened truss head.
- 4.2.4 TimberWood Structural Screws are Torx-driven screws with a flat countersinking head.

4.3 Fastener Material

- 4.3.1 Power Pro® LedgerTite® Structural Wood Screws, Power Pro® Structural Lag Screws, and Power Pro® TimberWood Structural Screws are made of hardened carbon steel.

4.4 Corrosion Resistance

- 4.4.1 Power Pro® LedgerTite® Structural Wood Screws, Power Pro® Structural Lag Screws, and Power Pro® TimberWood Structural Screws may be used where screws are required to exhibit corrosion resistance when exposed to adverse environmental conditions, which are subject to the limitations of this report. Power Pro® screws have been evaluated for use in wood treated with ACQ-D preservatives with a retention of 0.40 pcf (6.4 kg/m³) and may be used as an alternative to hot-dip galvanized fasteners in wood treated with preservatives or less corrosive effects meeting ASTM A153, Class D ([IBC Section 2304.10.6](#) and [IRC Section R317.3](#)).
- 4.4.2 Power Pro® LedgerTite® Structural Wood Screws, Power Pro® Structural Lag Screws, and Power Pro® TimberWood Structural Screws have a proprietary coating, which may be used as an alternative to the protection provided by code-approved hot-dipped galvanized coatings meeting ASTM A153, Class D ([IBC Section 2304.10.6](#) and [IRC Section R317.3](#)).

4.5 Pressure-Preservative Treated (PPT) Wood Applications

- 4.5.1 Power Pro® LedgerTite® Structural Wood Screws, Power Pro® Structural Lag Screws, and Power Pro® TimberWood Structural Screws having the proprietary coating are recognized for use in PPT lumber provided the conditions set forth by the PPT lumber manufacturer are met, including appropriate strength reductions.

4.6 Fire-Retardant Treated (FRT) Wood Applications

- 4.6.1 Power Pro® LedgerTite® Structural Wood Screws, Power Pro® Structural Lag Screws, and Power Pro® TimberWood Structural Screws having the proprietary coating are recognized for use in FRT lumber provided the conditions set forth by the FRT lumber manufacturer are met, including appropriate strength reductions.

4.7 Wood Members

- 4.7.1 Solid sawn wood members connected with Power Pro® LedgerTite® Structural Wood Screws, Power Pro® Structural Lag Screws, and Power Pro® TimberWood Structural Screws shall consist of lumber species or species combinations having a specific gravity of 0.42 to 0.55.
- 4.7.2 Structural composite lumber (i.e., LVL, LSL, PSL, etc.) connected with Power Pro® LedgerTite® Structural Wood Screws, Power Pro® Structural Lag Screws, and Power Pro® TimberWood Structural Screws shall be recognized in evaluation reports having published equivalent specific gravities for lateral and withdrawal resistance. Equivalent specific gravities for structural composite lumber may be used in the design of connections using the specific gravities of the sawn lumber shown in Table 2.

4.8 Fastener Specifications

4.8.1 Table 1 lists the dimensions and mechanical properties of Power Pro® LedgerTite® Structural Wood Screws, Power Pro® Structural Lag Screws, and Power Pro® TimberWood Structural Screws that are evaluated in this TER.

Table 1. Fastener Specifications

Fastener Name	Nominal Diameter (in)	Length ¹ (in)	Thread Length ² (in)	Head Diameter ³ (in)	Unthreaded Shank Diameter (in)	Thread Diameter (in)		Nominal Bending Yield (psi)	Tensile Strength (lbf)	
						Minor	Major		ASD	LFRD
Power Pro® LedgerTite® Structural Wood Screws	5/16	3 ⁵ / ₈	2.00	0.610	0.204	0.181	0.284	180,000	970	1,460
		5	3.00							
Power Pro® Structural Lag Screws	5/16	3 ¹ / ₂	2.20	0.630	0.204	0.181	0.284	180,000	970	1,460
		4	2.60							
		5	3.50							
		6	4.00							
Power Pro® TimberWood Structural Screws	5/16	3	2.10	0.630	0.204	0.181	0.284	180,000	970	1,460
		4	2.60							
		5	3.50							
		6	4.00							

SI: 1 in = 25.4 mm, 1 psi = 0.00689 MPa, 1 lbf = 4.448 N

1. Measured from the underside of the head to the tip
2. Includes tip.
3. Nominal diameter of the washer head.

5 Applications

5.1 General

- 5.1.1 Power Pro® LedgerTite® Structural Wood Screws, Power Pro® Structural Lag Screws, and Power Pro® TimberWood Structural Screws are designed to attach the deck ledger to the band joist of a building in accordance with [IBC Section 1604.8.3](#) and [IRC Section R507.9](#).¹¹
- 5.1.1.1 Where a band joist is not used, as in some truss installations, an engineered design is required. See Appendix B: Code Requirements for Ledger Attachments for additional code requirements for ledger attachments.
- 5.1.2 The IRC provides prescriptive fastener spacing for the attachment of a deck ledger to a band joist with 1/2" diameter lag screws or through bolts as shown in [IRC Table R507.9.1.3\(1\)](#).¹²
- 5.1.2.1 Table 2 provides the spacing required to provide performance at least equivalent to the lag screws found in [IRC Table R507.9.1.3\(1\)](#) in accordance with [IBC Section 104.11](#), [IBC Section 1604.8.3](#), [IRC Section R104.11](#) and [IRC Section R507.9](#),¹³ and in accordance with generally accepted engineering practice.
- 5.1.2.1.1 Table 2 provides screw spacing for materials found in [IRC Section R507.9](#), as well as a wider range of materials commonly used for rim joists. Screw spacing values are provided for four loading conditions.
- 5.1.2.2 When installed in accordance with the spacing requirements of Table 2, the listed Power Pro® LedgerTite® Structural Wood Screws, Power Pro® Structural Lag Screws, and Power Pro® TimberWood Structural Screws provide equivalent performance to [IRC Table R507.9.1.3\(1\)](#).
- 5.1.3 Unless otherwise noted, adjustment of the design stresses for duration of load shall be in accordance with the applicable code.
- 5.1.3.1 In addition, an alternate loading condition (i.e., deck snow load = 60 psf, deck dead load = 10 psf) required by some jurisdictions is shown.
- 5.1.4 Power Pro® LedgerTite® Structural Wood Screws, Power Pro® Structural Lag Screws, and Power Pro® TimberWood Structural Screws are installed without lead holes.
- 5.1.4.1 When a bored hole is desired to prevent splitting of wood, provisions in the NDS Chapter 12 shall be followed.

¹¹ [2015 IRC Section R507.2](#)

¹² [2015 IRC Table R507.2](#)

¹³ [2015 IRC Section R507.2](#)

Table 2. Fastener Spacings for Deck Ledger Attachment

Fastener	Loading Condition (psf)	2x Nominal Ledger Species ⁷	Band Joist Material ^{3,8}	Maximum On-center Spacing of Power Pro® Structural Wood Screws (in)						
				Maximum Deck Joist Spans ^{1,2,4,5,6}						
				Up to 6'	Up to 8'	Up to 10'	Up to 12'	Up to 14'	Up to 16'	Up to 18'
LedgerTite® or Structural Lag Screw or TimberWood Structural Screw	LL + DL 40 + 10	DF/SP	Sawn Lumber / SCL	20	15	12	10	8	7	6
		HF/SPF	Sawn Lumber / SCL	16	12	9	8	7	6	5
	SL + DL 50 + 10	DF/SP	Sawn Lumber/SCL	19	14	11	9	8	7	6
		HF/SPF	Sawn Lumber / SCL	15	11	9	7	6	5	5
	SL + DL 60 + 10	DF/SP	Sawn Lumber / SCL	16	12	10	8	7	6	5
		HF/SPF	Sawn Lumber / SCL	13	10	8	6	5	5	4
	SL + DL 70 + 10	DF/SP	Sawn Lumber / SCL	14	10	8	7	6	5	4
		HF/SPF	Sawn Lumber / SCL	11	8	7	5	5	4	3

SI: 1 in = 25.4 mm, 1 psf = 0.0479 kN/m²

- Based on load duration, C_d, of 1.0 for live load conditions, and 1.15 for snow load conditions. Spacing may be adjusted by the applicable load duration for other conditions as specified in the NDS. Fastener spacings are applicable to Power Pro® LedgerTite® Structural Wood Screws, Power Pro® Structural Lag Screws, and Power Pro® TimberWood Structural Screws.
- Fasteners are required to have full thread penetration into the main member. Minimum fastener length to be used is 3".
- Solid sawn band joists shall be HF/SPF or SP/DF species (Specific gravity of 0.42 and 0.50 respectively).
- Fastener spacing is based on published design values from approved agencies.
- Fasteners shall be staggered from the top to the bottom along the length of the ledger while maintaining the required edge and end distances shown in Figure 4.
- A maximum 1/2" structural sheathing may be installed between the ledger and the band joist.
- Minimum ledger board requirements: 1.5" thickness and 7.25" depth.
- Minimum band joist requirements: Specific gravity of 0.42 for sawn lumber and 0.50 for SCL. ; Sawn lumber band joist 1.5" thick and 7.25" depth; SCL band joist 1.0" thick and 7.25 depth

5.1.5 Allowable loads for deck ledger to stud connections installed with Power Pro® LedgerTite® Structural Wood Screws, Power Pro® Structural Lag Screws, and Power Pro® TimberWood Structural Screws are presented in Table 3.

5.1.5.1 Values in Table 3 apply where the ledger is installed either directly over the studs or with up to two layers of 5/8" gypsum wallboards between the ledger and studs.

Table 3. Power Pro® Structural Wood Screws, Allowable Loads for Ledger to Stud Attachment, with or without Gypsum Wallboard (GWB)

Fastener	Fastener Size	Penetration into Main Member (in)	Layers of GWB ⁷	Allowable Load per Stud Connection ^{3,4,5,6} (lbf)	
				Ledger Size ^{1,2}	
				2x6 or 2x8	2x10
LedgerTite®	5/16" x 3 5/8"	2 1/8	0	360	540
		1 1/2	1	235	353
	5/16" x 5"	2 7/8	1	260	390
		2 1/4	2	190	285
Structural Lag Screw or TimberWood Structural Screw	5/16" x 3"	1 1/2	0	310	465
	5/16" x 3 1/2"	2	0	360	540
	5/16" x 4"	2 1/2	0	360	540
		1 7/8	1	260	390
	5/16" x 5"	2 7/8	1	260	390
		2 1/4	2	190	285
		3 1/4	2	190	285

SI: 1 in = 25.4 mm, 1 lbf = 4.448 N

- Two fasteners are required for 2"x6" and 2"x8" ledger connections. Three fasteners are required for 2"x10" ledger connections. Additional fasteners are prohibited.
- Ledger and studs with minimum specific gravity of 0.42.
- The tabulated values apply where the ledger is installed either directly over the studs or with up to two layers of 5/8" gypsum between the ledger and studs.
- Allowable loads shall be limited to parallel-to-grain loaded solid sawn main members (minimum 2" nominal). Wood side members shall be loaded perpendicular to grain.
- Allowable loads are shown at the wood load duration factor of $C_D = 1.0$. Loads may be increased for load duration as permitted by the building code up to a $C_D = 1.60$. All adjustment factors shall be applied per NDS. For in-service moisture content greater than nineteen percent (19%), use Wet Service Factor (C_M) = 0.70.
- Fasteners shall be centered in the stud and spaced as shown in Figure 5 through Figure 15. The stud minimum end distance is 6 3/4" when loaded toward the end and 4" when loaded away from the end. The ledger end distance is 6" for full values. For ledger end distances under 6", the reference connection design values shall be adjusted in accordance with NDS Section 12.5.
- GWB must be attached as required per the building code.

5.2 Where the application falls outside of the performance evaluation, conditions of use and/or installation requirements set forth herein, alternative techniques shall be permitted in accordance with accepted engineering practice and experience. This includes but is not limited to the following areas of engineering: mechanics or materials, structural, building science, and fire science.

6 Installation

- 6.1 Installation shall comply with the approved construction documents, the manufacturer installation instructions, this TER and the applicable building code.
- 6.2 In the event of a conflict between the manufacturer installation instructions and this TER, the more restrictive shall govern.
- 6.3 For applications outside the scope of this TER, an engineered design is required.
- 6.4 *Deck Ledger to Band Joist Installation Procedure*
 - 6.4.1 Choose a Power Pro® LedgerTite® Structural Wood Screws, Power Pro® Structural Lag Screws, and Power Pro® TimberWood Structural Screws of sufficient length so that the threads fully engage the rim material and the fastener tip extends beyond the back face of the rim material when fully seated against the installed ledger board.
 - 6.4.2 Drive the fasteners through the ledger and exterior sheathing. Continue into the rim joist until the head is drawn firm and the topside of the head is flush to the surface of the ledger board. Do not overdrive.
 - 6.4.2.1 Lead holes are not required but may be used where lumber is prone to splitting using the provisions in the NDS.
 - 6.4.3 Stagger the fasteners from the top to the bottom along the length of the ledger while maintaining the required edge and end distances as shown in Figure 4 and Figure 5.
 - 6.4.4 As an example, Figure 4 shows a detail of the Power Pro® LedgerTite® Structural Wood Screw deck connection, including minimum edge and end distances.

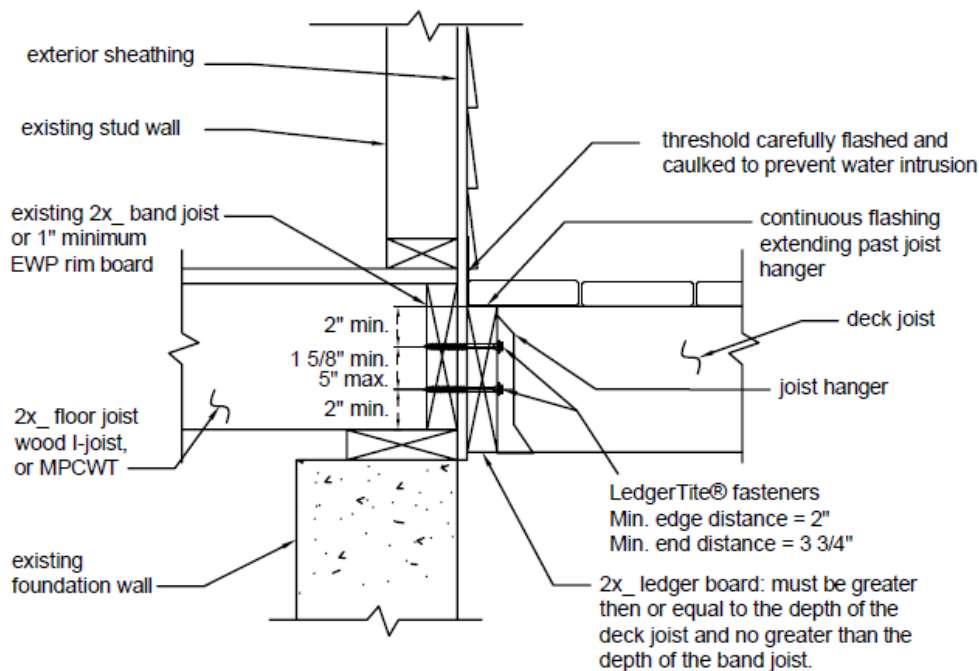

Figure 4. Power Pro® LedgerTite® Structural Wood Screws Deck Connection

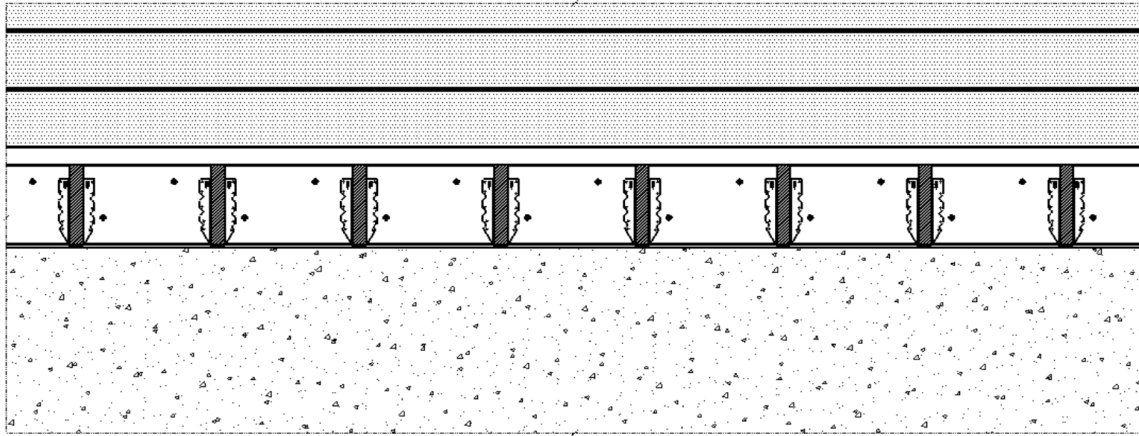

Figure 5. Power Pro® LedgerTite® Structural Wood Screws Deck Connection (Front-View)

6.5 Ledger to Stud Installation Procedure

6.5.1 Choose a Power Pro® fastener listed in Table 3.

6.5.2 Fasteners shall be centered in the stud.

6.5.2.1 The stud minimum end distance is $6\frac{3}{4}$ " when loaded toward the end and 4" when loaded away from the end.

6.5.2.2 Fasteners shall be installed with a minimum end distance of 6" on the ledger.

6.5.3 *Without GWB Interlayer:*

6.5.3.1 Installation details for ledger to stud connections without GWB for 2"x6", 2"x8", and 2"x10" ledgers are shown in Figure 6, Figure 7 and Figure 8, respectively.

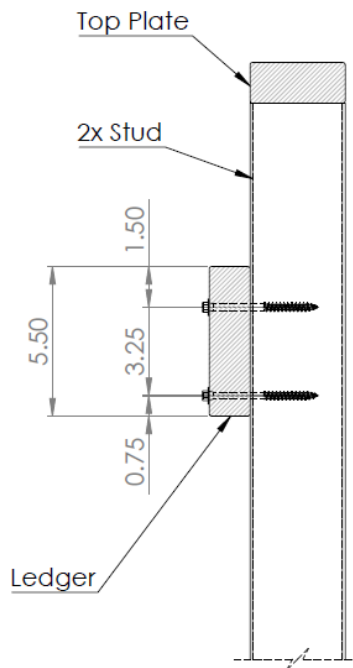

Figure 6. 2"x6" Ledger Directly Attached to Stud

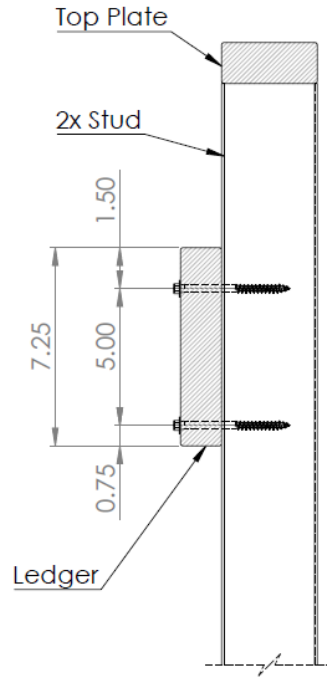

Figure 7. 2"x8" Ledger Directly Attached to Stud

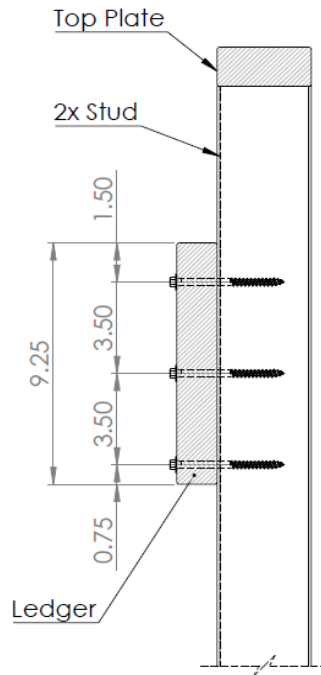

Figure 8. 2"x10" Ledger Directly Attached to Stud

6.5.4 With One Layer GWB Interlayer:

6.5.4.1 Installation details for ledger to stud connections with a single layer of GWB for 2"x6", 2"x8", and 2"x10" ledgers are shown in Figure 9, Figure 10 and Figure 11, respectively.

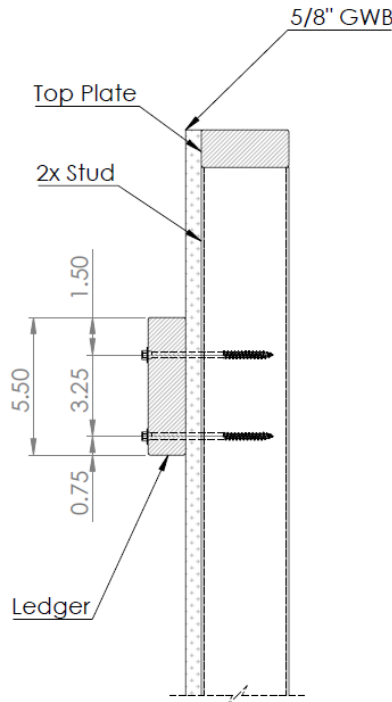

Figure 9. 2"x6" Ledger Attached to Stud through One Layer of GWB

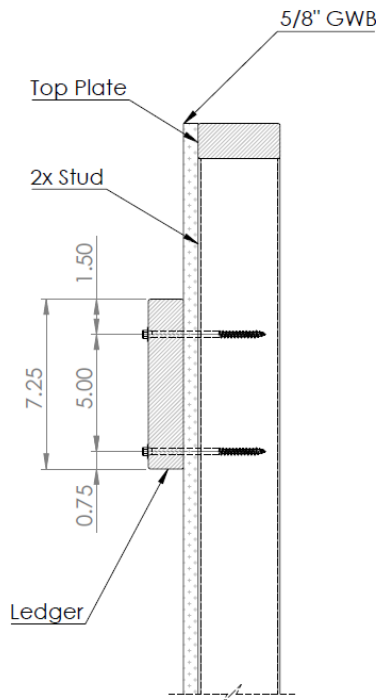

Figure 10. 2"x8" Ledger Attached to Stud through One Layer of GWB

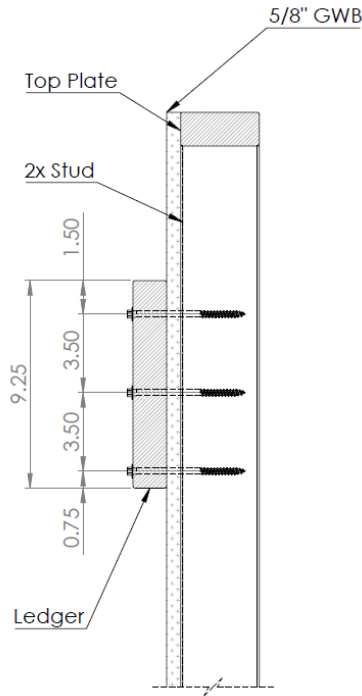

Figure 11. 2"x10" Ledger Attached to Stud through One Layer of GWB

6.5.5 *With Two Layers GWB Interlayer:*

- 6.5.5.1 Installation details for ledger to stud connections with a double layer of GWB for 2"x6", 2"x8", and 2"x10" ledgers are shown in Figure 12, Figure 13 and Figure 14, respectively.
- 6.5.5.2 An example of the spacing pattern is presented in Figure 15.

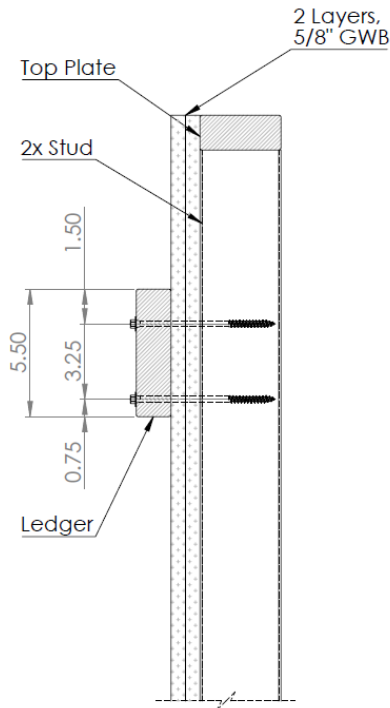

Figure 12. 2"x6" Ledger Attached to Stud through Two Layers of GWB

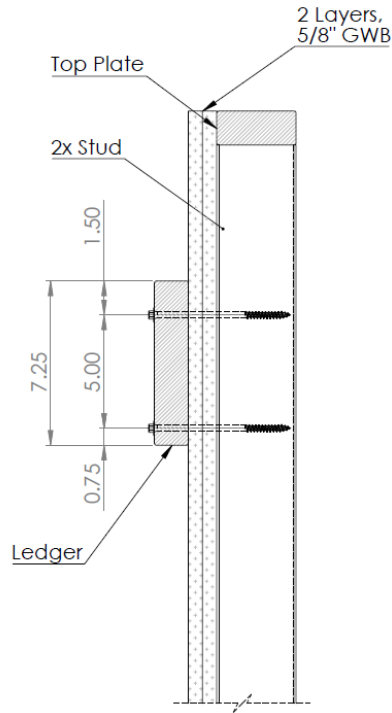

Figure 13. 2"x8" Ledger Attached to Stud through Two Layers of GWB

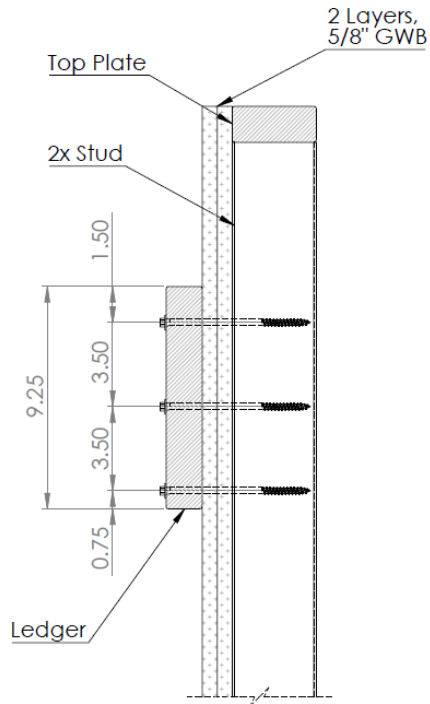

Figure 14. 2"x10" Ledger Attached to Stud through Two Layers of GWB

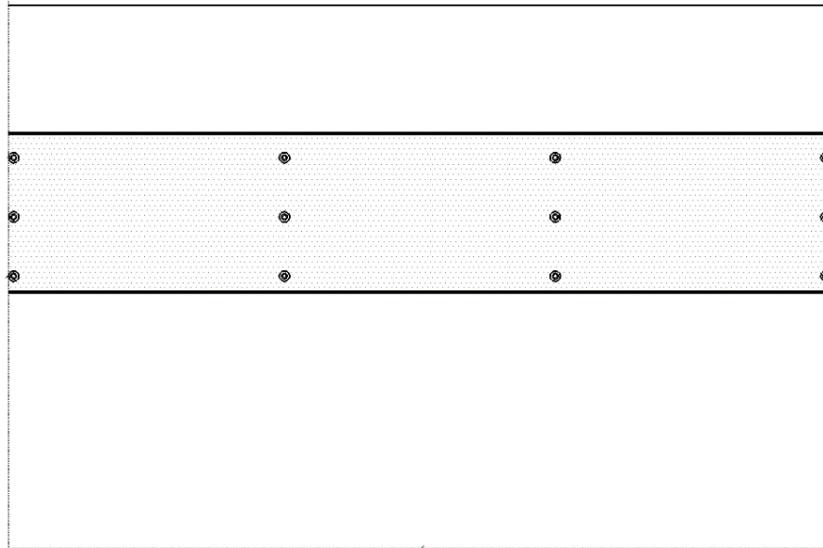

Figure 15. 2"x10" Ledger Attached to Stud through Two Layers of GWB (Front-View)

6.6 General Guidelines

- 6.6.1 Fasteners shall be installed with the topside of the head flush to the surface of the wood member.
- 6.6.2 Fasteners shall not be overdriven.
- 6.6.3 Fasteners shall not be struck with a hammer during installation.
- 6.6.4 Lead holes are not required but may be used where lumber is prone to splitting using the provisions in the NDS.

7 Substantiating Data

- 7.1 Testing has been performed under the supervision of a professional engineer and/or under the requirements of ISO/IEC 17025 as follows:
 - 7.1.1 Properties for Power Pro® LedgerTite® Structural Wood Screws, Power Pro® Structural Lag Screws, and Power Pro® TimberWood Structural Screws were obtained from approved sources.
 - 7.1.2 Connection design value calculations by DrJ Engineering, LLC in accordance with NDS and accepted engineering practices.
- 7.2 Information contained herein may include the result of testing and/or data analysis by sources that are approved agencies (i.e., ANAB accredited agencies), approved sources (i.e., RDPs), and/or professional engineering regulations. Accuracy of external test data and resulting analysis is relied upon.
- 7.3 Where pertinent, testing and/or engineering analysis is based upon provisions that have been codified into law through state or local adoption of codes and standards. The developers of these codes and standards are responsible for the reliability of published content. DrJ's engineering practice may use a code-adopted provision as the control sample. A control sample versus a test sample establishes a product as being equivalent to the code-adopted provision in terms of quality, strength, effectiveness, fire resistance, durability, and safety.
- 7.4 The accuracy of the provisions provided herein may be reliant upon the published properties of raw materials, which are defined by the grade mark, grade stamp, mill certificate, Listings, certified reports, duly authenticated reports from approved agencies, and research reports prepared by approved agencies and/or approved sources provided by the suppliers of products, materials, designs, assemblies and/or methods of construction. These are presumed to be minimum properties and relied upon to be accurate. The reliability of DrJ's engineering practice, as contained in this TER, may be dependent upon published design properties by others.

- 7.5 Testing and engineering analysis: The strength, rigidity and/or general performance of component parts and/or the integrated structure are determined by suitable tests that simulate the actual conditions of application that occur and/or by accepted engineering practice and experience.¹⁴
- 7.6 Where additional condition of use and/or code compliance information is required, please search for Power Pro® LedgerTite® Structural Wood Screws, Power Pro® Structural Lag Screws, and Power Pro® TimberWood Structural Screws on the [DrJ Certification](#) website.

8 Findings

- 8.1 As delineated in Section 3, Power Pro® LedgerTite® Structural Wood Screws, Power Pro® Structural Lag Screws, and Power Pro® TimberWood Structural Screws have performance characteristics that were tested and/or meet pertinent standards and are suitable for use pursuant to its specified purpose.
- 8.2 When used and installed in accordance with this TER and the manufacturer installation instructions, Power Pro® LedgerTite® Structural Wood Screws, Power Pro® Structural Lag Screws, and Power Pro® TimberWood Structural Screws shall be approved for the following applications:
 - 8.2.1 As an alternative to the requirements of the [IBC Section 1604.8.3](#) and [IRC Section R507.9](#).¹⁵
 - 8.2.2 Connection of ledger boards to wall studs is suitable with zero, one, or two layers of 5/8" gypsum wallboard between the ledger and wall studs.
- 8.3 Unless exempt by state statute, when Power Pro® LedgerTite® Structural Wood Screws, Power Pro® Structural Lag Screws, and Power Pro® TimberWood Structural Screws are to be used as a structural and/or building envelope component in the design of a specific building, the design shall be performed by an RDP.
- 8.4 Any application specific issues not addressed herein can be engineered by an RDP. Assistance with engineering is available from The Hillman™ Group.
- 8.5 [IBC Section 104.11](#) ([IRC Section R104.11](#) and [IFC Section 104.10](#))¹⁶ are similar) in pertinent part states:

104.11 Alternative materials, design and methods of construction and equipment. The provisions of this code are not intended to prevent the installation of any material or to prohibit any design or method of construction not specifically prescribed by this code. Where the alternative material, design or method of construction is not approved, the building official shall respond in writing, stating the reasons the alternative was not approved.
- 8.6 **Approved:**¹⁷ Building codes require that the [building official](#) shall accept [duly authenticated reports](#)¹⁸ or [research reports](#)¹⁹ from [approved agencies](#) and/or [approved sources](#) (i.e., licensed RDP) with respect to the quality and manner of use of new products, materials, designs, services, assemblies, or methods of construction.
 - 8.6.1 [Acceptance](#) of an [approved agency](#), by a building official, is performed by verifying that the agency is accredited by a recognized accreditation body of the [International Accreditation Forum](#) (IAF).
 - 8.6.2 [Acceptance](#) of a licensed RDP, by a building official, is performed by verifying that the RDP and/or their business entity is listed by the [licensing board](#) of the relevant [jurisdiction](#).
 - 8.6.3 Federal law, [Title 18 US Code Section 242](#), requires that where the alternative product, material, service, design, assembly, and/or method of construction is not approved, the building official shall respond in writing, stating the reasons why the alternative was not approved, as denial without written reason deprives a protected right to free and fair competition in the marketplace.

¹⁴ See Code of Federal Regulations (CFR) [Title 24 Subtitle B Chapter XX Part 3280](#) for definition.

¹⁵ [2015 IRC Section 507.2](#)

¹⁶ [2018 IFC Section 104.9](#)

¹⁷ Approved is an adjective that modifies the noun after it. For example, Approved Agency means that the Agency is accepted officially as being suitable in a particular situation. This example conforms to IBC/IRC/IFC [Section 201.4](#) where the building code authorizes sentences to have an ordinarily accepted meaning such as the context implies.

¹⁸ <https://up.codes/viewer/wyoming/ibc-2021/chapter/17/special-inspections-and-tests#1707.1>

¹⁹ <https://up.codes/viewer/wyoming/ibc-2021/chapter/17/special-inspections-and-tests#1703.4.2>

- 8.7 DrJ is an engineering company, employs RDPs and is an ISO/IEC 17065 ANAB-Accredited Product Certification Body – Accreditation #1131.
- 8.8 Through ANAB accreditation and the IAF Multilateral Agreements, this TER can be used to obtain product approval in any jurisdiction or country that has IAF MLA Members & Signatories to meet the Purpose of the MLA – “*certified once, accepted everywhere.*” IAF specifically says, “*Once an accreditation body is a signatory of the IAF MLA, it is required to recognise certificates and validation and verification statements issued by conformity assessment bodies accredited by all other signatories of the IAF MLA, with the appropriate scope.*”²⁰

9 Conditions of Use

- 9.1 Material properties shall not fall outside the boundaries defined in Section 3.
- 9.2 As defined in Section 3, where material and/or engineering mechanics properties are created for load resisting design purposes, the resistance to the applied load shall not exceed the ability of the defined properties to resist those loads using the principles of accepted engineering practice.
- 9.3 For deck ledger connections, Power Pro® fastener spacing shall not exceed the values listed in Table 2 and the provisions detailed in Section 6.
- 9.4 When Power Pro® fasteners are installed into studs, loads shall not exceed those listed in Table 3.
- 9.5 As listed herein, Power Pro® LedgerTite® Structural Wood Screws, Power Pro® Structural Lag Screws, and Power Pro® TimberWood Structural Screws can be used in:
- 9.5.1 Chemically (pressure preservatives and fire-retardants) treated and untreated wood in exterior use conditions.
- 9.6 When installed in preservative-treated wood or fire-retardant-treated wood, connections shall be designed using the treatment manufacturer reductions for connections.
- 9.7 For conditions not covered in this TER, connections shall be designed in accordance with generally accepted engineering practices. When the capacity of a connection is controlled by fastener metal strength rather than wood strength, the metal strength shall not be increased by the adjustment factors specified in the NDS.
- 9.8 When required by adopted legislation and enforced by the building official, also known as the authority having jurisdiction (AHJ) in which the project is to be constructed:
- 9.8.1 Any calculations incorporated into the construction documents shall conform to accepted engineering practice, and, when prepared by an approved source, shall be approved when signed and sealed.
- 9.8.2 This TER and the installation instructions shall be submitted at the time of permit application.
- 9.8.3 These innovative products have an internal quality control program and a third-party quality assurance program.
- 9.8.4 At a minimum, these innovative products shall be installed per Section 6 of this TER.
- 9.8.5 The review of this TER, by the AHJ, shall be in compliance with IBC Section 104 and IBC Section 105.4.
- 9.8.6 These innovative products have an internal quality control program and a third party quality assurance program in accordance with IBC Section 104.4, IBC Section 110.4, IBC Section 1703, IRC Section R104.4 and IRC Section R109.2.
- 9.8.7 The application of these innovative products in the context of this TER are dependent upon the accuracy of the construction documents, implementation of installation instructions, inspection as required by IBC Section 110.3, IRC Section R109.2 and any other regulatory requirements that may apply.
- 9.9 The approval of this TER by the AHJ shall comply with IBC Section 1707.1, where legislation states in pertinent part, “*the building official shall accept duly authenticated reports from approved agencies in respect to the quality and manner of use of new materials or assemblies as provided for in Section 104.11*”, all of IBC Section 104, and IBC Section 105.4.

²⁰ <https://iaf.nu/en/about-iaf-mla/#:~:text=required%20to%20recognise>

- 9.10 Design loads shall be determined in accordance with the building code adopted by the jurisdiction in which the project is to be constructed and/or by the building designer (i.e., owner or RDP).
- 9.11 The actual design, suitability, and use of this TER, for any particular building, is the responsibility of the owner or the owner's authorized agent.

10 Identification

- 10.1 The innovative products listed in Section 1.1 through Section 1.3 are identified by a label on the board or packaging material bearing the manufacturer name, product name, TER number, and other information to confirm code compliance.
- 10.2 Additional technical information can be found at www.hillmangroup.com.

11 Review Schedule

- 11.1 This TER is subject to periodic review and revision. For the most recent version, visit drjcertification.org.
- 11.2 For information on the status of this TER, contact [DrJ Certification](#).

12 Approved for Use Pursuant to US and International Legislation Defined in Appendix A

- 12.1 Power Pro® LedgerTite® Structural Wood Screws, Power Pro® Structural Lag Screws, and Power Pro® TimberWood Structural Screws are included in this TER published by an approved agency that is concerned with evaluation of products or services, maintains periodic inspection of the production of listed materials or periodic evaluation of services, and whose TER Listing states either that the material, product, or service meets identified standards or has been tested and found suitable for a specified purpose. This TER meets the legislative intent and definition of being acceptable to the AHJ.

Appendix A

1 Legislation that Authorizes AHJ Approval

- 1.1 **Fair Competition:** State legislatures have adopted Federal regulations for the examination and approval of building code referenced and alternative products, materials, designs, services, assemblies and/or methods of construction that:
- 1.1.1 Advance Innovation,
 - 1.1.2 Promote competition so all businesses have the opportunity to compete on price and quality in an open market on a level playing field unhampered by anticompetitive constraints, and
 - 1.1.3 Benefit consumers through lower prices, better quality, and greater choice.
- 1.2 **Adopted Legislation:** The following local, state, and federal regulations affirmatively authorize Power Pro® LedgerTite® Structural Wood Screws, Power Pro® Structural Lag Screws, and Power Pro® TimberWood Structural Screws to be approved by AHJs, delegates of building departments, and/or delegates of an agency of the federal government:
- 1.2.1 Interstate commerce is governed by the Federal Department of Justice to encourage the use of innovative products, materials, designs, services, assemblies and/or methods of construction. The goal is to “protect economic freedom and opportunity by promoting free and fair competition in the marketplace.”
 - 1.2.2 Title 18 US Code Section 242 affirms and regulates the right of individuals and businesses to freely and fairly have new products, materials, designs, services, assemblies and/or methods of construction approved for use in commerce. Disapproval of alternatives shall be based upon non-conformance with respect to specific provisions of adopted legislation, and shall be provided in writing stating the reasons why the alternative was not approved, with reference to the specific legislation violated.
 - 1.2.3 The federal government and each state have a public records act. In addition, each state also has legislation that mimics the federal Defend Trade Secrets Act 2016 (DTSA),²¹ where providing test reports, engineering analysis and/or other related IP/TS is subject to prison of not more than 10 years²² and/or a \$5,000,000 fine or 3 times the value of²³ the Intellectual Property (IP) and Trade Secrets (TS).
 - 1.2.3.1 Compliance with public records and trade secret legislation requires approval through the use of listings, certified reports, Technical Evaluation Reports, duly authenticated reports and/or research reports prepared by approved agencies and/or approved sources.
 - 1.2.4 For new materials²⁴ that are not specifically provided for in any building code, the design strengths and permissible stresses shall be established by tests, where suitable load tests simulate the actual loads and conditions of application that occur.
 - 1.2.5 The design strengths and permissible stresses of any structural material shall conform to the specifications and methods of design using accepted engineering practice.²⁵
 - 1.2.6 The commerce of approved sources (i.e., registered PEs) is regulated by professional engineering legislation. Professional engineering commerce shall always be approved by AHJs, except where there is evidence, provided in writing, that specific legislation has been violated by an individual registered PE.
 - 1.2.7 The AHJ shall accept duly authenticated reports from approved agencies in respect to the quality and manner of use of new materials or assemblies as provided for in IBC Section 104.11.²⁶

²¹ <http://www.drjengineering.org/AppendixC> and <https://www.drjcertification.org/cornell-2016-protection-trade-secrets>.

²² <https://www.law.cornell.edu/uscode/text/18/1832#:~:text=imprisoned%20not%20more%20than%2010%20years>

²³ <https://www.law.cornell.edu/uscode/text/18/1832#:~:text=Any%20organization%20that,has%20thereby%20avoided>

²⁴ <https://up.codes/viewer/wyoming/ibc-2021/chapter/17/special-inspections-and-tests#1706.2>

²⁵ [IBC 2021, Section 1706.1 Conformance to Standards](#)

²⁶ [IBC 2021, Section 1707 Alternative Test Procedure, 1707.1 General](#)

- 1.3 **Approved²⁷ by Los Angeles:** The Los Angeles Municipal Code (LAMC) states in pertinent part that the provisions of LAMC are not intended to prevent the use of any material, device, or method of construction not specifically prescribed by LAMC. The Department shall use Part III, Recognized Standards in addition to Part II, Uniform Building Code Standards of Division 35, Article 1, Chapter IX of the LAMC in evaluation of products for approval where such standard exists for the product or the material and may use other approved standards, which apply. Whenever tests or certificates of any material or fabricated assembly are required by Chapter IX of the LAMC, such tests or certification shall be made by a testing agency approved by the Superintendent of Building to conduct such tests or provide such certifications. The testing agency shall publish the scope and limitation(s) of the listed material or fabricated assembly.²⁸ The Superintendent of Building roster of approved testing agencies is provided by the Los Angeles Department of Building and Safety (LADBS). The Center for Building Innovation (CBI) Certificate of Approval License is TA24945. Tests and certifications found in a CBI Listing are LAMC approved. In addition, the Superintendent of Building shall accept duly authenticated reports from approved agencies in respect to the quality and manner of use of new materials or assemblies as provided for in the California Building Code (CBC) Section 1707.1.²⁹
- 1.4 **Approved by Chicago:** The Municipal Code of Chicago (MCC) states in pertinent part that an Approved Agency is a Nationally Recognized Testing Laboratory (NRTL) acting within its recognized scope and/or a certification body accredited by the American National Standards Institute (ANSI) acting within its accredited scope. Construction materials and test procedures shall conform to the applicable standards listed in the MCC. Sufficient technical data shall be submitted to the building official to substantiate the proposed use of any product, material, service, design, assembly and/or method of construction not specifically provided for in the MCC. This technical data shall consist of research reports from approved sources (i.e., MCC defined Approved Agencies).
- 1.5 **Approved by New York City:** The NYC Building Code 2022 (NYCBC) states in pertinent part that an approved agency shall be deemed³⁰ an approved testing agency via ISO/IEC 17025 accreditation, an approved inspection agency via ISO/IEC 17020 accreditation, and an approved product evaluation agency via ISO/IEC 17065 accreditation. Accrediting agencies, other than federal agencies, must be members of an internationally recognized cooperation of laboratory and inspection accreditation bodies subject to a mutual recognition agreement³¹ (i.e., ANAB, International Accreditation Forum (IAF), etc.).
- 1.6 **Approved by Florida:** Statewide approval of products, methods, or systems of construction shall be approved, without further evaluation, by 1) A certification mark or listing of an approved certification agency, 2) A test report from an approved testing laboratory, 3) A product evaluation report based upon testing or comparative or rational analysis, or a combination thereof, from an approved product evaluation entity; 4) A product evaluation report based upon testing or comparative or rational analysis, or a combination thereof, developed and signed and sealed by a professional engineer or architect, licensed in Florida. For local product approval, products or systems of construction shall demonstrate compliance with the structural wind load requirements of the Florida Building Code (FBC) through one of the following methods; 1) A certification mark, listing, or label from a commission-approved certification agency indicating that the product complies with the code; 2) A test report from a commission-approved testing laboratory indicating that the product tested complies with the code; 3) A product-evaluation report based upon testing, comparative or rational analysis, or a combination thereof, from a commission-approved product evaluation entity which indicates that the product evaluated complies with the code; 4) A product-evaluation report or certification based upon testing or comparative or rational analysis, or a combination thereof, developed and signed and sealed by a Florida professional engineer or Florida registered architect, which indicates that the product complies with the code; 5) A statewide product approval issued by the Florida Building Commission. The Florida Department of Business and Professional Regulation (DBPR) website provides a listing of companies certified as a Product Evaluation Agency (i.e., EVLMiami 13692), a Product Certification Agency (i.e., CER10642), and as a Florida Registered Engineer (i.e., ANE13741).

²⁷ See Section 8 for the distilled building code definition of Approved

²⁸ Los Angeles Municipal Code, SEC. 98.0503. TESTING AGENCIES

²⁹ https://up.codes/viewer/california/ca-building-code-2022/chapter/17/special-inspections-and-tests#1707.1

³⁰ New York City, The Rules of the City of New York, § 101-07 Approved Agencies

³¹ New York City, The Rules of the City of New York, § 101-07 Approved Agencies

- 1.7 **Approved by Miami-Dade County (i.e., Notice of Acceptance [NOA]):** A Florida statewide approval is an NOA. An NOA is a Florida local product approval. By Florida law, Miami-Dade County shall accept the statewide and local Florida Product Approval as provided for in Florida legislation [553.842](#) and [553.8425](#).
- 1.8 **Approved by New Jersey:** Pursuant to Building Code 2018 of New Jersey in [IBC Section 1707.1 General](#),³² it states: “In the absence of approved rules or other approved standards, the building official shall accept duly authenticated reports from [approved agencies](#) in respect to the quality and manner of use of new materials or assemblies as provided for in the administrative provisions of the [Uniform Construction Code \(N.J.A.C. 5:23\)](#)”.³³ Furthermore N.J.A.C 5:23-3.7 states: Municipal approvals of alternative materials, equipment, or methods of construction. **(a) Approvals:** Alternative materials, equipment, or methods of construction shall be approved by the appropriate subcode official provided the proposed design is satisfactory and that the materials, equipment, or methods of construction are suitable for the intended use and are at least the equivalent in quality, strength, effectiveness, fire resistance, durability and safety of those conforming with the requirements of the regulations.
1. A field evaluation label and report or letter issued by a nationally recognized testing laboratory verifying that the specific material, equipment, or method of construction meets the identified standards or has been tested and found to be suitable for the intended use, shall be accepted by the appropriate subcode official as meeting the requirements of (a) above.
2. Reports of engineering findings issued by nationally recognized evaluation service programs, such as, but not limited to, the Building Officials and Code Administrators (BOCA), the International Conference of Building Officials (ICBO), the Southern Building Code Congress International (SBCCI), the International Code Council (ICC), and the National Evaluation Service, Inc., shall be accepted by the appropriate subcode official as meeting the requirements of (a) above. The [New Jersey Department of Community Affairs](#) has confirmed that technical evaluation reports, from any accredited entity listed by [ANAB](#), meets the requirements of item 2 given that the listed entities are no longer in existence and/or do not provide “reports of engineering findings”.
- 1.9 **Approved by the Code of Federal Regulations Manufactured Home Construction and Safety Standards:** Pursuant to Title 24, Subtitle B, Chapter XX, [Part 3282.14](#),³⁴ and [Part 3280](#),³⁵ the Department encourages innovation and the use of new technology in manufactured homes. The design and construction of a manufactured home shall conform with the provisions of Part 3282 and Part 3280 where key approval provisions in mandatory language follow: 1) “All construction methods shall be in conformance with accepted engineering practices”; 2) “The strength and rigidity of the component parts and/or the integrated structure shall be determined by engineering analysis or by suitable load tests to simulate the actual loads and conditions of application that occur.”; and 3) “The design stresses of all materials shall conform to accepted engineering practice.”
- 1.10 **Approval by US, Local, and State Jurisdictions in General:** In all other local and state jurisdictions, the adopted building code legislation states in pertinent part that:
- 1.10.1 For [new materials](#) that are not specifically provided for in this code, the [design strengths and permissible stresses](#) shall be established by tests.³⁶
- 1.10.2 For [innovative alternative products, materials, designs, services and/or methods of construction](#), in the absence of approved rules or other approved standards...the building official shall accept duly authenticated reports (i.e., listing and/or research report) from [approved agencies](#) with respect to the quality and manner of use of [new materials or assemblies](#).³⁷ A building official [approved agency](#) is deemed to be approved via certification from an [accreditation body](#) that is listed by the [International Accreditation Forum](#)³⁸ or equivalent.

³² https://up.codes/viewer/new_jersey/ibc-2018/chapter/17/special-inspections-and-tests#1707.1

³³ <https://www.nj.gov/dca/divisions/codes/codereg/ucc.html>

³⁴ <https://www.ecfr.gov/current/title-24/subtitle-B/chapter-XX/part-3282/subpart-A/section-3282.14>

³⁵ <https://www.ecfr.gov/current/title-24/subtitle-B/chapter-XX/part-3280>

³⁶ [IBC 2021, Section 1706 Design Strengths of Materials, 1706.2 New Materials](#). Adopted law pursuant to IBC model code language 1706.2.

³⁷ [IBC 2021, Section 1707 Alternative Test Procedure, 1707.1 General](#). Adopted law pursuant to IBC model code language 1707.1.

³⁸ Please see the [ANAB directory](#) for building official approved agencies.

- 1.10.3 The design strengths and permissible stresses of any structural material...shall conform to the specifications and methods of design of accepted engineering practice performed by an approved source.³⁹ An approved source is defined as a PE subject to professional engineering laws, where a research and/or a technical evaluation report certified by a PE, shall be approved.
- 1.11 **Approval by International Jurisdictions:** The USMCA and GATT agreements provide for approval of innovative materials, products, designs, services, assemblies and/or methods of construction through the Technical Barriers to Trade agreements and the International Accreditation Forum (IAF) Multilateral Recognition Arrangement (MLA), where these agreements:
- 1.11.1 Permit participation of conformity assessment bodies located in the territories of other Members (defined as GATT Countries) under conditions no less favourable than those accorded to bodies located within their territory or the territory of any other country,
 - 1.11.2 State that conformity assessment procedures (i.e., ISO/IEC 17020, 17025, 17065, etc.) are prepared, adopted, and applied so as to grant access for suppliers of like products originating in the territories of other Members under conditions no less favourable than those accorded to suppliers of like products of national origin or originating in any other country, in a comparable situation.
 - 1.11.3 State that conformity assessment procedures are not prepared, adopted, or applied with a view to or with the effect of creating unnecessary obstacles to international trade. This means that conformity assessment procedures shall not be more strict or be applied more strictly than is necessary to give the importing Member adequate confidence that products conform to the applicable technical regulations or standards.
 - 1.11.4 **Approved:** The purpose of the IAF MLA is to ensure mutual recognition of accredited certification and validation/verification statements between signatories to the MLA, and subsequently acceptance of accredited certification and validation/verification statements in many markets based on one accreditation for the timely approval of innovative materials, products, designs, services, assemblies and/or methods of construction. Accreditations granted by IAF MLA signatories are recognised worldwide based on their equivalent accreditation programs, therefore reducing costs and adding value to businesses and consumers.

³⁹ IBC 2021, Section 1706 Design Strengths of Materials, Section 1706.1 Conformance to Standards Adopted law pursuant to IBC model code language 1706.1.

Appendix B

Code Requirements for Ledger Attachments

For guidance on designing the connection of the deck ledger to trusses where a band joist is not used, see SBCA's Tech Note: Attachment of Residential Deck Ledger to Metal Plate Connected Wood Truss Floor System.

1.1 IRC Section R507.8⁴⁰ contains the following code requirements (IBC Section 1604.8.3 is similar):

1.1.1 Where supported by attachment to an exterior wall, decks shall be positively anchored to the primary structure and designed for both vertical and lateral loads.

1.1.1.1 Attachment shall not be accomplished by the use of toenails or nails subject to withdrawal.

1.2 IRC Section R507.9.1 details how vertical loads shall be transferred to band joists with ledgers:

1.2.1 IRC Section R507.9.1.1:

Deck ledgers shall be a minimum 2-inch by 8-inch (51 mm by 203 mm) nominal, pressure-preservative-treated Southern pine, incised pressure-preservative-treated hem-fir, or approved, naturally durable, No. 2 grade or better lumber...

1.2.2 IRC Section R507.9.1.2⁴¹:

Band joists supporting a ledger shall be a minimum 2-inch-nominal (51 mm), spruce-pine-fir or better lumber or a minimum 1-inch (25 mm) nominal engineered wood rim boards in accordance with Section R502.1.7. Band joists shall bear fully on the primary structure capable of supporting all required loads.

1.2.3 IRC Section R507.9.1.3:

Fasteners used in deck ledger connections in accordance with Table R507.9.1.3(1) shall be hot-dipped galvanized or stainless steel and shall be installed in accordance with Table R507.9.1.3(2) and Figures R507.9.1.3(1) and R507.9.1.3(2).

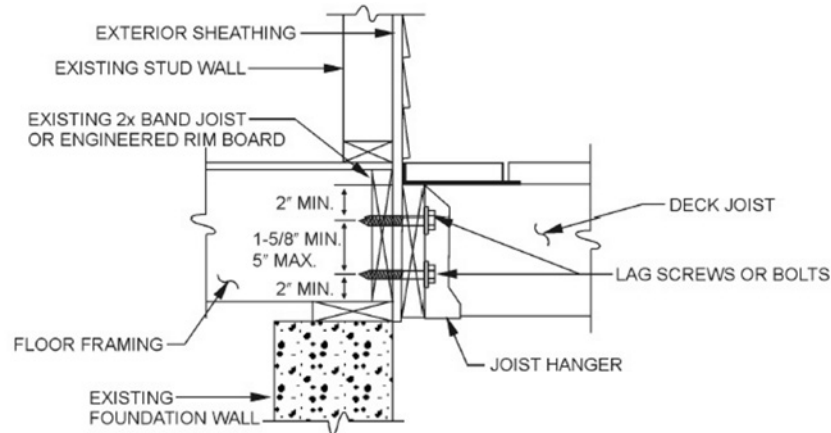

For SI: 1 inch = 25.4 mm.

Figure 16. IRC Figure R507.9.1.3(2): Placement of Lag Screws and Bolts in Band Joists

⁴⁰ 2015 IRC Section R507.1

⁴¹ 2015 IRC Section R507.2

1.2.4 IRC Table R507.9.1.3(1) and Table R507.9.1.3(2)⁴² cover the placement of lag screws or bolts in deck ledgers:

The tip of the lag screw shall fully extend beyond the inside face of the band joist.

Lag screws or bolts shall be staggered from the top to the bottom along the horizontal run of the deck ledger in accordance with Figure R507.9.1.3(1).

The minimum distance from bottom row of lag screws or bolts to the top edge of the ledger shall be in accordance with Figure R507.9.1.3(1).

CONNECTION DETAILS	JOIST SPAN						
	6' and less	6'1" to 8'	8'1" to 10'	10'1" to 12'	12'1" to 14'	14'1" to 16'	16'1" to 18'
	On-center spacing of fasteners						
1/2-inch diameter lag screw with 1/2-inch maximum sheathing ^{c, d}	30	23	18	15	13	11	10
1/2-inch diameter bolt with 1/2-inch maximum sheathing ^d	36	36	34	29	24	21	19
1/2-inch diameter bolt with 1-inch maximum sheathing ^e	36	36	29	24	21	18	16

For SI: 1 inch = 25.4 mm, 1 foot = 304.8 mm, 1 pound per square foot = 0.0479 kPa.

- a. Ledgers shall be flashed in accordance with Section R703.4 to prevent water from contacting the house band joist.
- b. Snow load shall not be assumed to act concurrently with live load.
- c. The tip of the lag screw shall fully extend beyond the inside face of the band joist.
- d. Sheathing shall be wood structural panel or solid sawn lumber.
- e. Sheathing shall be permitted to be wood structural panel, gypsum board, fiberboard, lumber or foam sheathing. Up to 1/2-inch thickness of stacked washers shall be permitted to substitute for up to 1/2 inch of allowable sheathing thickness where combined with wood structural panel or lumber sheathing.

Figure 17. Table R507.9.1.3(1): Deck Ledger Connection to Band Joist_{A,B}
(Deck live load = 40 psf, deck dead load = 10 psf, snow load ≤ 40 psf)

MINIMUM END AND EDGE DISTANCES AND SPACING BETWEEN ROWS				
	TOP EDGE	BOTTOM EDGE	ENDS	ROW SPACING
Ledger ^a	2 inches ^d	3/4 inch	2 inches ^b	1 ⁵ / ₈ inches ^b
Band Joist ^c	3/4 inch	2 inches	2 inches ^b	1 ⁵ / ₈ inches ^b

For SI: 1 inch = 25.4 mm.

- a. Lag screws or bolts shall be staggered from the top to the bottom along the horizontal run of the deck ledger in accordance with Figure R507.9.1.3(1).
- b. Maximum 5 inches.
- c. For engineered rim joists, the manufacturer's recommendations shall govern.
- d. The minimum distance from bottom row of lag screws or bolts to the top edge of the ledger shall be in accordance with Figure R507.9.1.3(1).

Figure 18. Table R507.9.1.3(2): Placement of Lag Screws and Bolts in Deck Ledgers and Band Joists

⁴² 2015 IRC Section R507.2

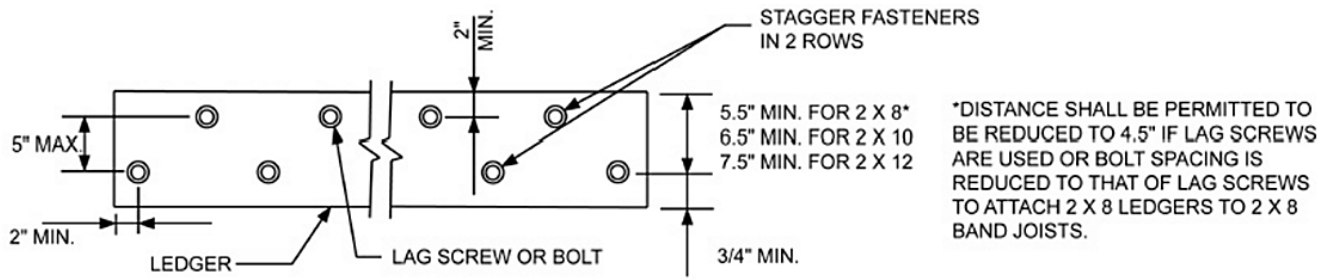

For SI: 1 inch = 25.4 mm.

Figure 19. Figure IRC R507.9.1.3(1): Placement of Lag Screws and Bolts in Ledgers